

AVVM31B Thermostatic shower mixer with slide rail kit

Barcode	7081246985255
Product Code	AVVM31B
Construction	Brass Body (CuZn38Pb18)
Finishes	Chrome plated to BS EN 248
Product Type	Contemporary
Water Pressure	Min. 0.5 bar, Max. 6.0 bar
Plumbing Systems	Suitable for all plumbing systems, preferably balanced. Min. supply pressure differential requirement is 5:1
Standards	Complies with BSEN 1111
Certification	WRAS (1710082) and TMV2 (NSF1917/1017) approved and certified
Cartridge	Thermostatic
Fitting	Easy Fit
Diverter	Ceramic disc
Check valve	0.5-10 gpm
Packaging	73x31.5x39.5cm/carton (10pcs), Box size: 71.5x15x7.5cm, Weight: 2.46kg/pcs
Guarantee	10 years against manufacturing faults (excluding serviceable parts).
Additional Information	<ol style="list-style-type: none"> 1. Temperature: Pre-set 38°C, with push button override to 48°C 2. Automatic shut off in the event of hot or cold water supply failure 3. Shower handset : Chrome, ABS, 3 modes 4. Shower hose : Stainless steel , chrome , 1.5m 5. Stainless steel slider rail

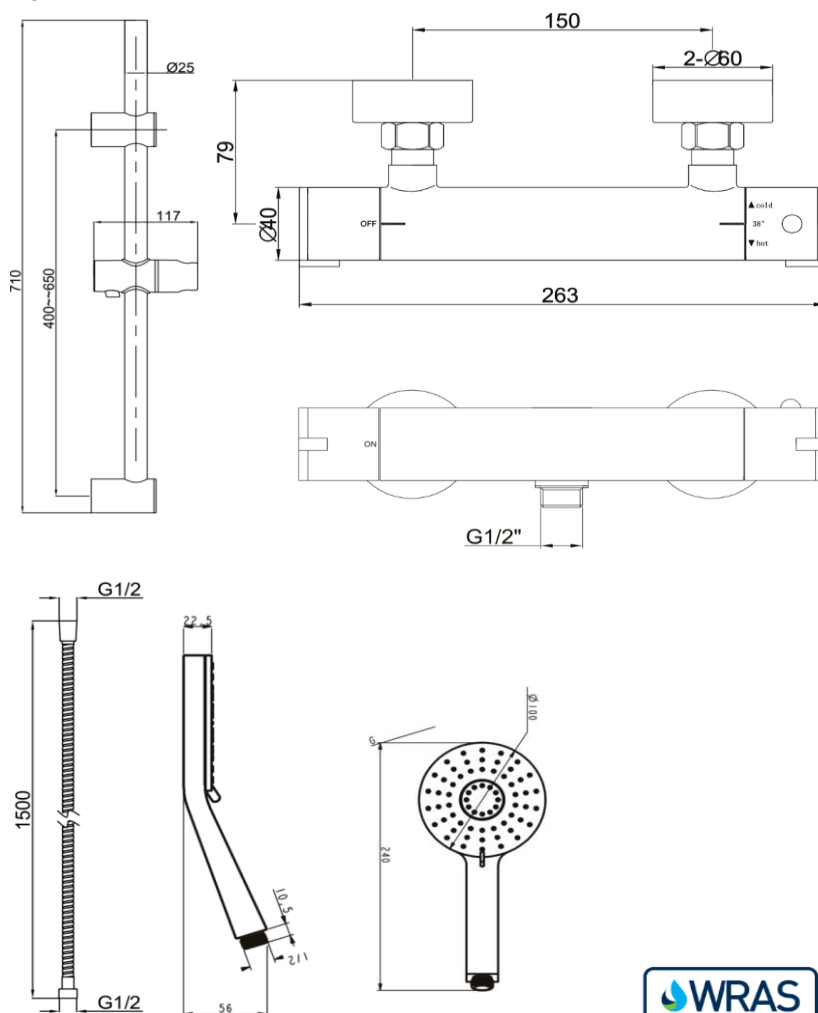

Flow Rates (Litres per minute)

System Pressure	0.1 Bar	0.2 Bar	0.3 Bar	0.5 Bar	1.0 Bar	1.5 Bar	2.0 Bar	3.0 Bar	4.0 Bar	5.0 Bar
AVVM31B	6.0	7.0	-	8.5	12.0	14.0	18.5	22.0	-	-

The information contained on this page was correct at date of issue. Fitting dimensions are provided as a guide only. Some variation may occur due to manufacturing tolerances. We pursue a policy of continuing improvement in design and performance of our products and so reserve the right to change specifications without prior notice.